

Type CDT

Time-Lag Ceramic Tube Micro Fuses Series

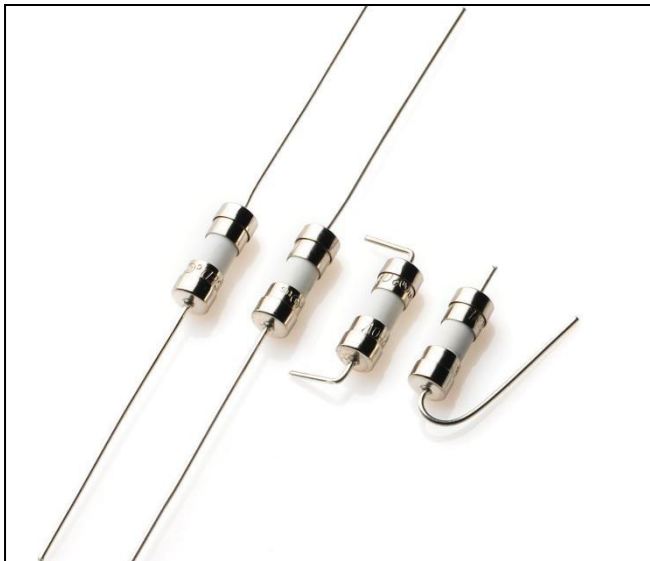

Description

CDT Time-lag Ceramic Tube Type 250V rated designed in accordance to IEC60127.3, GB/T9364.3, UL 248-14.

Features

- Lead-free
- Internationally approved
- Reduced PCB space requirements
- Direct Solderability or plug-in versions
- Low internal resistance
- Shock safe casing
- Vibration resistant
- Halogen free

Applications

- Power supplies
- Battery Chargers
- Consumer Electronics
- Industrial Controllers
- Adapter

Agency Approvals

Safety Agency	Agency File Number	Ampere Range Volt@I.R.ABILITY
	R 50487196	250mA~10A 50A@250V AC 250mA~10A 50A@300V AC
	2020970207000099	250mA~3.15A 35A@250V AC 4A~6.3A 10In@250V AC
	E485357	250mA~15A 50A@125V AC 250mA~15A 50A@250V AC 250mA~15A 50A@300V AC

Electrical Characteristics for Series

% of Ampere Rating	Opening Time
150%	1 Hour ,Min.
210%	2min,Max
275%	400ms Min,10s Max
400%	150ms Min,3s Max
1000%	20ms Min,150ms Max

Electrical Characteristic Specifications by item

Catalog Number	Rated Current	Voltage Rating	Breaking Capacity	Melting Integral 10In min(A2S)	Agency Approvals		
					TUV	CCC	cULus
CDT0250	250mA	125VAC 250VAC 300VAC	50A@125V AC 50A@250V AC 50A@300V AC	0.325	•	•	•
CDT0315	315mA			0.516	•	•	•
CDT0400	400mA			0.784	•	•	•
CDT0500	500mA			1.050	•	•	•
CDT0630	630mA			2.024	•	•	•
CDT0800	800mA			2.688	•	•	•
CDT1100	1A			4.200	•	•	•
CDT1125	1.25A			7.813	•	•	•
CDT1160	1.6A			12.544	•	•	•
CDT1200	2A			23.200	•	•	•
CDT1250	2.5A			35.000	•	•	•
CDT1315	3.15A			48.620	•	•	•
CDT1400	4A			73.600	•	•	•
CDT1500	5A			110.000	•	•	•
CDT1630	6.3A			170.667	•	•	•
CDT1700	7A			196.000			•
CDT1800	8A			256.000	•		•
CDT2100	10A			360.000	•		•
CDT2150	15A			450.000			•

Type CDT

Time-Lag Ceramic Tube Micro Fuses Series



Temperature Re-rating Curve

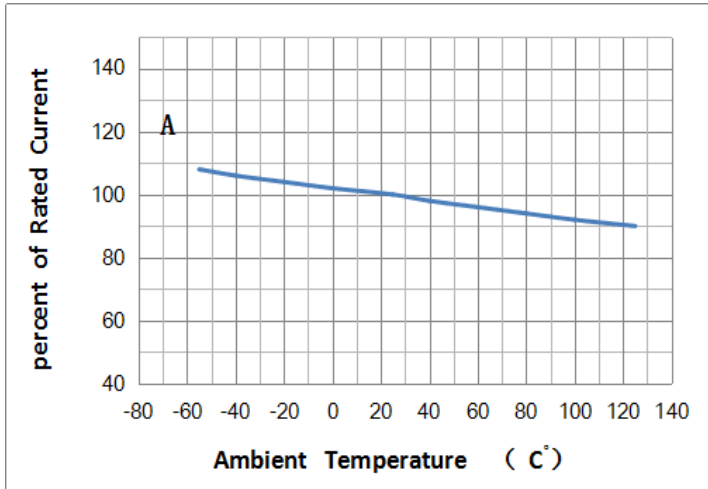

Average Time Current Curves

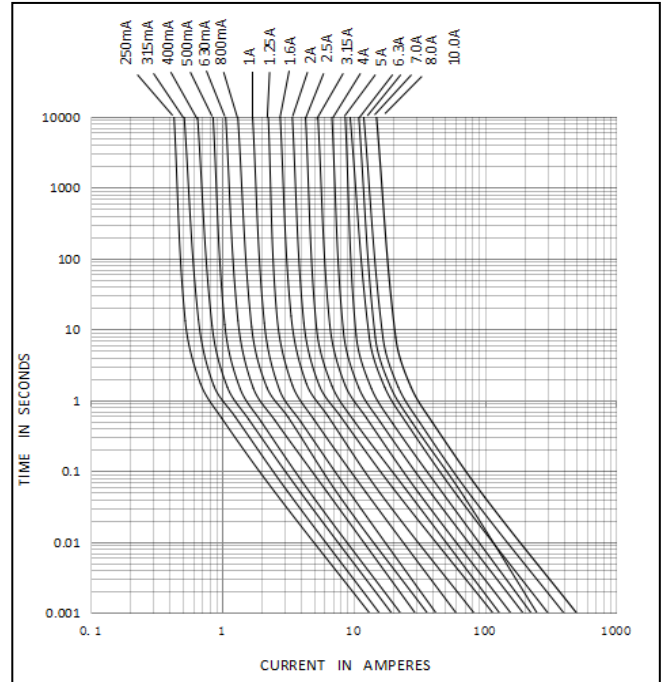

Soldering Parameters-Wave Soldering

Lead-Free Wave Soldering Profile	
Wave Soldering Parameter	
Average ramp-up rate	200°C/second
Heating rate during preheat	Typical 1-2°C/second Max 4°C/second
Final preheat temperature	Within 125°C of Soldering temperature
Peak temperature	260°C
Time within +0/-5°C of actual peak temperature	10 seconds
Ramp-down Rate	5°C/second max

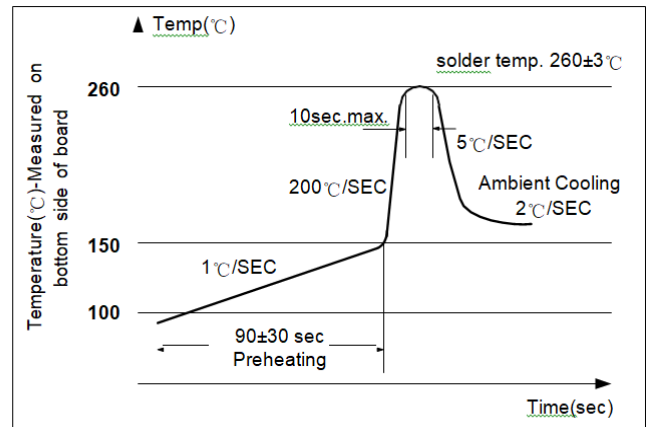

Type CDT

Time-Lag Ceramic Tube Micro Fuses Series



Product Characteristics

Materials	Ceramic Body Nickel Plated Brass Caps Lead Wire :Diameter 0.8mm、0.6mm
Lead Pull Strength	10 N(IEC 60068-2-21)
Soldering Parameters	260°C, ≤10 sec.(wave) 350°C, ≤3 sec.(soldering iron)
Soldering Heat Resistance	260°C, 10 sec.(IEC 60068-2-20) 350°C, ≤3 sec.(soldering iron)

Operating Temperature	-55°C to +125°C(consider de-rating)
Climatic Category	-40°C to +85°C/21 days (EN 60068-1, -2-1, -2-2, -2-78)
Stock Condition	+10°C to +60°C Relative humidity ≤75% yearly Average, without dew, maximum Value for 30 days-95%
Vibration Resistance	24 cycles at 15 min. each (EN 60068-2-6) 10-60 Hz at 0.75 mm amplitude 60-2000 Hz at 10 g acceleration

Mechanical Dimensions(Unit :mm)

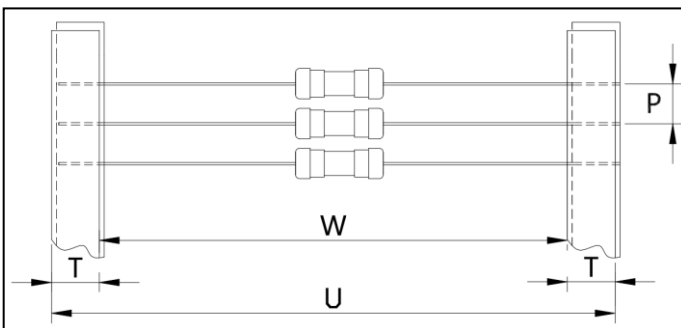
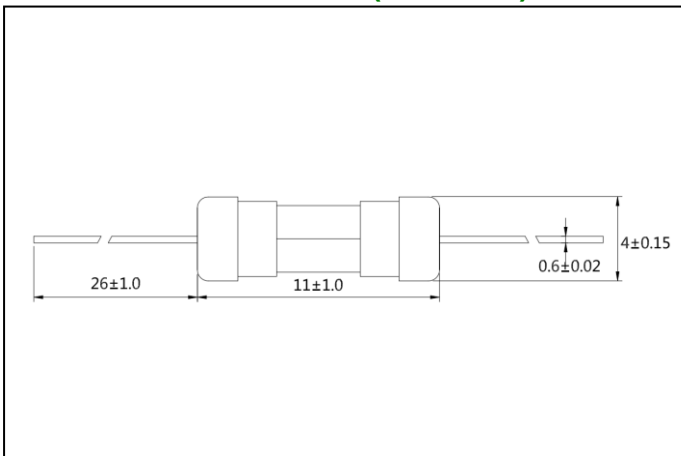

编带标准	W	U	T	P
T52	52 ± 1.5	65 ± 1.5	6 ± 0.2	5 ± 0.05
T60	60 ± 1.5	73.5 ± 1.5	6 ± 0.2	5 ± 0.05

Ordering Information

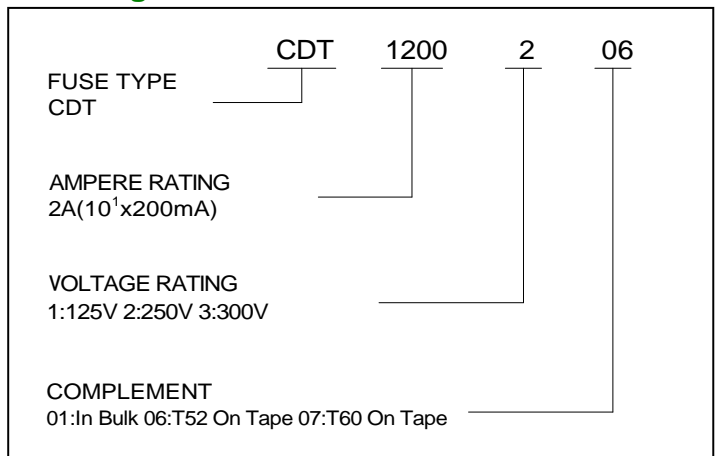

Packaging

Packaging Option	Packaging Specification	Quantity
On Tape	N / A	1000pcs & 1500pcs
In Bulk	N / A	300pcs